

V. Tytiuk^{*1},
orcid.org/0000-0003-1077-3288,
O. Chorny²,
orcid.org/0000-0001-8270-3284,
D. Mrachkovskiy³,
orcid.org/0000-0003-2811-0677,
S. Tryputen⁴,
orcid.org/0000-0003-3979-6512,
M. Tryputen⁵,
orcid.org/0000-0003-4523-927X,
V. Kuznetsov⁶,
orcid.org/0000-0002-8169-4598

1 – NJSC “Karaganda Industrial University”, Temirtau, the Republic of Kazakhstan
2 – Kremenchuk Mykhailo Ostrohradskiy National University, Kremenchuk, Ukraine
3 – Kryvyi Rih National University, Kryvyi Rih, Ukraine
4 – Neura Robotics GmbH, Metzingen, the Federal Republic of Germany
5 – Dnipro University of Technology, Dnipro, Ukraine
6 – Ukrainian State University of Science and Technologies, Dnipro, Ukraine
^{*} Corresponding author email: v.tytiuk@ttu.edu.kz

MATHEMATICAL MODEL OF THE CLOSED-LOOP SYSTEM OF EXCAVATOR BUCKET POSITIONING

Purpose. Study on energy consumption of mechatronic systems of mining excavators during the full production cycle, development of energy efficiency criterion for the production cycle of mining excavators, which ensures an increase in the technical and economic indicators of the operation of powerful mining equipment.

Methodology. Mathematical modeling of electro-mechanical system of “front shovel” excavator, determination indicators of the production cycle, development of the criterion of energy efficiency of the mining excavator’s operating cycle taking into account the theory of technical systems efficiency.

Findings. A mathematical model of a complete electro-mechanical system of an excavator with “generator-engine” electric drive has been developed, which includes a model of the mechanical part of the excavator. The closed-loop bucket positioning system makes it possible to implement various movement trajectories during the operating cycle. Numerical characteristics of energy consumption and duration for various movement trajectories of the working bodies of the excavator are obtained. A new criterion of energy efficiency of mechatronic systems of mining excavators is proposed.

Originality. For the first time, a mathematical model has been proposed of an integral electro-mechanical system of an excavator according to the “front shovel” scheme, which includes models of electric drives of all mechanisms and a synchronous drive motor, as well as a model of the mechanical part of the excavator; this makes it possible to increase the accuracy of determining the excavator’s energy consumption and the operating cycle time. A criterion of energy efficiency is proposed, which takes into account the amount of resource costs, the overall result and the duration of the excavator’s operating cycle.

Practical value. A mathematical model of the electromechanical system of an excavator with an electric drive according to the “generator-motor” system has been developed, which, taking into account the solution of the direct and inverse problems of the kinematics of the mechanical system of the excavator, makes it possible to compare parameters of various trajectories of movement of the excavator. The implementation of a closed system for positioning the excavator bucket in three-dimensional space was proposed, which creates conditions for increasing the level of automation of mining excavators. A criterion of the energy efficiency of the excavator’s technological cycle is proposed, which takes into account resource costs and the technological cycle duration.

Keywords: *excavator, mathematical model, trajectory parameters, energy efficiency*

Introduction. Excavators play an important role in open pit mining. The most powerful excavators are used in open pit mining for both stripping activity, rock mass transfer and dump formation [1].

In the mining industry, the transition to a new generation of production equipment is characterized by a functional and constructive combination of electromechanical converters with energy and information components with a high level of organization of control processes. During continuous development and complication of interconnected electrical, mechanical, electromechanical, and control systems, modern excavation machinery is being transformed into a mechatronic complex [2]. For mechatronic complexes of mining machines, due to their significant installed capacity, the energy efficiency of their operation is of particular importance.

Increasing the efficiency of using the electrical energy in industry and, consequently, in mechatronic systems of mining machines is a defining trend in the development of technical systems in the near future [3].

An analysis of modern scientific and technical literature shows that currently there are no developments of automatic control systems for the movement of the working bodies of mining excavators. In fact, the functions of controlling the

movement of the mining machines’ working bodies are assigned to the man-machine complex in which defining actions are assigned to the operator. Such a decision makes it impossible to analyze and synthesize control systems, which ensure the rational use of electricity in mechatronic systems, and limits the maximum achievable energy characteristics of mechatronic systems of mining machines.

In this regard, the development of automatic control systems for the movement of working bodies for mining machines that minimize the influence of the operator, is becoming the main direction in the development of electromechanical systems for mining equipment in general, and mining excavators in particular. At present, this task is of particular relevance in connection with the fundamental renewal of both the power equipment of excavator electric drives and technical controls.

Literature review. The analysis of modern scientific and technical literature demonstrates the significant interest of researchers in various problems of the operation of excavators. Work [4] is devoted to the kinematic analysis of the mechanical part of the excavator according to the “backhoe” scheme for closed-loop position control systems. In [5], the features of the interconnected operation of the mechanical part of the main mechanisms of the excavator according to the “front shovel” scheme are considered.

In [6], the problem of the influence of variable loads on the technical condition and reliability of the elements of the crowd

© Tytiuk V., Chorny O., Mrachkovskiy D., Tryputen S., Tryputen M., Kuznetsov V., 2023

mechanism and the excavator as a whole is studied. Various aspects of the problem of developing autonomous or remotely controlled excavator systems are considered.

Works [7] consider the influence of the qualification of the operator on productivity and energy consumption of excavator.

The work [8] is devoted to the problems of analyzing the wear of excavator equipment; in [9], the wear of the elements of the bucket and the crowd mechanism that directly interact with the rock mass is considered in more detail.

Energy calculation remains the most complex and critical stage in the design of mechatronic systems. Currently, it is carried out using particular methods [10], which do not take into account the settings of control devices and the features of power converters.

For electric drive systems with semiconductor converters, operation of which causes distortions in the shape of currents and voltages, both calculations and measurements of energy characteristics are difficult, since models and estimates of the parameters of electric power processes for nonlinear systems do not have unambiguous and generally accepted definitions [11].

In [12], the problems of synthesis of mechatronic control systems that are optimal in terms of minimum energy consumption are considered, which is a complex task that depends on the size and configuration of the mechatronic system.

It should be noted that now there are no generally accepted definitions of the energy efficiency of technical systems and criteria for its determination in the scientific community.

As shown in [13], a minimum of energy consumption is not identical to an increase in the energy efficiency of technical systems.

In [14], a criterion for the energy efficiency of the process of starting powerful electric drives is proposed, taking into account various types of resource costs, the cumulative result and the duration of the starting process.

In modern scientific and technical literature, there are no works devoted to the synthesis of a closed-loop system for automatic control of the position of a “front shovel” excavator bucket, which limits the perspectives for optimizing this type of equipment.

Purpose. The purpose of the work is to create a mathematical model of a closed-loop excavator bucket positioning system based on the solution of the direct and inverse problems of the kinematics of the mechanical part of the excavator according to the “front shovel” scheme to determine and further optimize technical and economic indicators during the production cycle of mining excavators.

To achieve this goal, it is necessary to solve the following tasks:

- to obtain solutions of the direct and inverse kinematic problems of the mechanical part of the “front shovel” excavator, linking the position of the individual mechanisms of the excavator with the position of the bucket in three-dimensional space;
- to develop mathematical models of closed-loop control systems for the positioning of individual mechanisms of the excavator;
- to develop a mathematical model of energy consumption of the electromechanical system of the excavator during the full production cycle;
- to determine the numerical characteristics of the main types of resource costs and the duration of the full production cycle for various trajectories of the bucket.

Justification of the design scheme of the mathematical model of the excavator’s electromechanical system. The choice of the type of excavator equipment is determined by the mining and geological conditions of minerals extraction: the shape and depth of deposits, the hardness of mined ore, the adopted development scheme and other factors. At the mining enterprises of Ukraine, which are characterized by high hardness of the extracted iron ore raw materials, electric excavators according to the “front shovel” scheme are most common. At the enterprises

of South and North America, hydraulic excavators according to the “backhoe” scheme have become more common.

Currently, two electric drive systems are the most common for the main mechanisms of an excavator: an electric drive according to the “generator-motor” system (Ward Leonard System), and the “thyristor converter-motor” (TC-DC) electric drive succeeding it. Despite the popularity and simplicity of mathematical modeling of a DC machine, the development of a model of a complete electromechanical system of an excavator is not an easy task, which is due to the complex composition of electromechanical equipment, the widespread use of multi-motor electric drives, and the presence of complex relationships between individual mechanisms in the mechanical part of the excavator [5].

The most common types of powerful mining excavators in the conditions of Ukrainian mining enterprises are front shovel excavators – EKG-5, EKG-8, EKG-10, EKG-12.5, EKG-20. These excavators have a similar design of the main mechanisms, differing in geometric dimensions and minor structural elements.

The following investigation will be carried out in relation to the EKG-8I excavator; in our opinion, it is the most common model of a mining excavator in the conditions of the Kryvyi Rih iron ore basin.

The current structure of the fleet of excavators in operation in the quarries of the Kryvyi Rih iron ore basin is shown in Table 1.

As can be seen from Table 1, about 65 % of the excavator fleet are EKG-8 and EKG-10 excavators, which have the same design dimensions and composition of electromechanical equipment.

Geometric dimensions and technical characteristics of the electromechanical equipment of the EKG-8I excavator. Further calculations will be performed on the example of one of the most common excavators of the EKG-8I type with an electric drive according to the “generator-motor” system.

Simplified kinematic diagram of the mechanisms of the “front shovel” excavator is presented in Fig. 1. The position of the excavator bucket in space is completely described by the three-dimensional coordinates of the digging point K .

The design and overall dimensions of the EKG-8I excavator are given in Table 2.

Below, Tables 3–5 show the technical characteristics of the electrical equipment of the excavator, that are necessary for the implementation of the mathematical model of the excavator.

Direct and inverse problems of excavator kinematics according to the “front shovel” scheme. The hoist of the excavator shovel, Fig. 1, is carried out by changing the swing angle φ_p around the axis passing through point 1, perpendicular to the plane of the figure. The extension and retraction of the shovel occurs during linear movement in the saddle bearing located at point 1, and is carried out by linear movement of the shovel L_N . The platform rotates around a vertical axis passing through its center of mass and is carried out by changing the swing angle φ_T .

Since the working bodies of the excavator perform two different swing movements, it is most natural to consider the movement of the working bodies of the excavator in a spherical coordinate system.

The center of the spherical coordinate system of the excavator is located at point O on the axis of swing of the platform at a height equal to the height of the attachment of the bottom of the boom, Fig. 2.

In this case, the coordinate φ will be equal to the angle of swing of the excavator platform, the coordinate will be equal to the length of the segment OK , the coordinate ϑ will be equal to the angle KOX (angle φ_E).

With such an arrangement of the center of the coordinate system and the accepted direction of the coordinate axes in Cartesian orthogonal coordinate system, the excavator standing level is characterized by a negative value of the Z coordinate.

Direct problem of excavator kinematics. It is necessary to determine the Cartesian coordinates of the position of the bucket position point $K(X, Y, Z)$ from the given values of the control

Table 1

Structure of the excavator fleet of the Kryvyi Rih iron ore basin

Company	EKG-5	EKG-8	EKG-10	EKG-12	Esh (walking excavator)	Hydraulics	Total
Inhulets HZK	2	10	25	7	–	–	44
Pivdennyi HZK	7	13	14	–	–	1	35
Tsentralnyi HZK (Petrovskiyi and Artemivskiyi quarries)	–	9	5	8	2	–	24
Tsentralnyi HZK (Hleevatskiy quarry)	–	9	3	4	2	–	18
Arcelor	7	4	9	1	–	3	24
Pivnichnyi HZK (Pervomaiskiyi and Annovskiyi quarries)	7	16	6	11	1	2	43
TOTAL	23	61	62	31	5	6	188
Share of excavator type, %	12.23	32.45	32.98	16.49	2.66	3.19	100

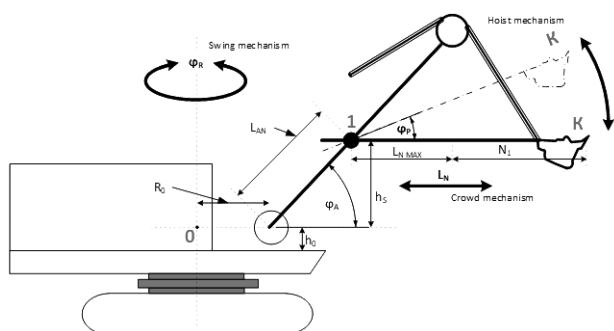

Fig. 1. Simplified kinematic diagram of the mechanisms of the "front shovel" excavator

coordinates of the excavator – linear movement of the shovel L_N , the angle of the boom φ_P , the swing angle of the platform φ_T .

Let us examine how the coordinates r and ϑ of the spherical coordinate system are related to the angle of the boom φ_P and the linear movement of the shovel L_N .

Let us determine the coordinates of point K in the ZOY coordinate system.

$$\begin{cases} K_X = R_0 + L_{AN} \cdot \cos(\varphi_A) + (L_N + N_1) \cdot \cos(\varphi_P) \\ K_Z = L_{AN} \cdot \sin(\varphi_A) + (L_N + N_1) \cdot \sin(\varphi_P) \end{cases} \quad (1)$$

Then the spherical coordinates of the point can be defined as follows

$$\begin{aligned} r &= \sqrt{K_X^2 + K_Z^2}; \\ \vartheta &= \arctan(K_Z / K_X). \end{aligned} \quad (2)$$

Table 2

Design dimensions of the EKG-8I excavator

Parameter	Value
Boom length, m	13.35
φ_A – Boom angle, deg	47
Handle length, m	11.425
Stick stroke, m	4.3
L_{Nmin} – minimum value of the stick stroke, m	0
L_{Nmax} – maximum value of the stick stroke, m	4.3
φ_{Pmin} – minimum value of the elevation angle, deg	–90
φ_{Pmax} – maximum value of the elevation angle, deg	45
φ_{Tmin} – minimum value of the swing angle, deg	0
φ_{Tmax} – maximum value of the swing angle, deg (determined by the parameters of the coalface)	120

Table 3

Specifications of the synchronous drive motor SDE 2-15-34-6U2

Motor model	SDE 2-15-34-6U2
Power, kWt	630
Rated stator voltage, V	6000
Rated current, A	71
Rated swing speed, rpm	1000
Efficiency, %	93.8

Table 4

Specifications of generators EKG-8I

No.	Drive	Hoist	Crowd	Swing
1	Generator type	PEM-151-8K	PEM-2000M	PEM-141-4K
2	Rated generator power, kW	500	115	250
3	Rated swing speed, rpm	1000	1000	1000
4	Rated armature voltage, V	560	330	630
5	Rated armature current, A	895	348	397
6	Rated efficiency, %	0.932	0.92	0.925
7	Number of pole pairs	3	2	2
8	Armature winding resistance, R_{AG} , Ohm	0.0075	0.0112	0.0355
9	Resistance of additional poles R_{APG} , Ohm	0.00153	0.00385	0.0054
10	Compensation winding resistance R_{CWG} , Ohm	0.00516	–	0.0139

Table 5

Specifications of drive motors EKG-81

Drive	Hoist	Crowd	Swing
Motor type	2 × DE-816	DE-816	2 × VE-812
Rated power, kW	2 × 190	100	2 × 100
Rated swing speed, rpm	720	750	750
Rated voltage, V	2 × 300	305	2 × 305
Number of pole pairs	2	2	2
Armature winding resistance, Ohm	2 × 0.0055	0.014	2 × 0.014
Resistance of additional poles, Ohm	0.0032	0.009	2 × 0.009

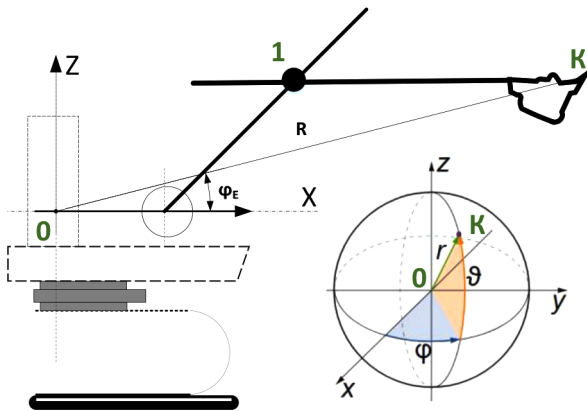

Fig. 2. Spherical coordinate system associated with the excavator platform

The transition from a spherical coordinate system to three-dimensional Cartesian coordinates is carried out using well-known expressions

$$\begin{cases} X = r \cdot \cos(\vartheta) \cdot \cos(\varphi_T) \\ Y = r \cdot \cos(\vartheta) \cdot \sin(\varphi_T) \\ Z = r \cdot \sin(\vartheta) \end{cases} \quad (3)$$

Formulas (1–3) give us a closed-loop solution to the direct problem of the excavator kinematics and determine the equation for converting the control coordinates of the excavator ($L_N, \varphi_P, \varphi_T$) into the Cartesian coordinates of the digging point $K(X, Y, Z)$.

Inverse problem of excavator kinematics. It is necessary to determine the control coordinates of the excavator ($L_N, \varphi_P, \varphi_T$) according to the given Cartesian position coordinates of the digging point $K(X, Y, Z)$.

The transition to spherical coordinates from Cartesian coordinates is carried out using well-known expressions

$$\begin{cases} \varphi_T = \text{atan}\left(\frac{Y}{X}\right) \\ \vartheta = \text{atan}\left(\frac{Z}{\sqrt{X^2 + Y^2}}\right) \\ r = \sqrt{X^2 + Y^2 + Z^2} \end{cases} \quad (4)$$

Using equation (2), we obtain the following relations

$$\begin{cases} K_X = \frac{1}{\sqrt{1 + \text{tg}^2(\vartheta)}} \\ K_Z = \frac{\text{tg}(\vartheta)}{\sqrt{1 + \text{tg}^2(\vartheta)}} \end{cases} \quad (5)$$

And finally, based on equations (1), we obtain

$$\begin{cases} \varphi_P = \text{atan}\left(\frac{K_Z - L_{AN} \cdot \sin(\varphi_A)}{K_X - R_0 - L_{AN} \cdot \cos(\varphi_A)}\right) \\ L_N = \frac{K_X - R_0 - L_{AN} \cdot \cos(\varphi_A)}{\cos(\varphi_P)} - N_1 \\ \varphi_T = \text{atan}\left(\frac{Y}{X}\right) \end{cases} \quad (6)$$

When solving the inverse problem of the excavator kinematics, we must take into account the fact that not all points in space (X, Y, Z) are achievable, which is due to the existence of design restrictions on the coordinates of the excavator.

Therefore, equations (4–6) must be supplemented by the following restrictions

$$\begin{cases} L_{N \min} \leq L_N \leq L_{N \max} \\ \varphi_{P \min} \leq \varphi_P \leq \varphi_{P \max} \\ \varphi_{T \min} \leq \varphi_T \leq \varphi_{T \max} \end{cases} \quad (7)$$

Equations (4–6), taking into account restrictions (7), give us a closed-loop solution of the inverse problem of the excavator kinematics.

Modeling of closed-loop control systems for the position of individual excavator mechanisms. To implement a mathematical model of both individual mechanisms of an excavator and an integral electromechanical system of an excavator, it is advisable to use the MATLAB/Simulink program using the SimPower library, since it contains pre-made implementations of the elements we need (power transformers, DC electrical machines, semiconductor converters of various types) and provides the ability to automatically generate a system of equations for multicomponent systems with different schemes for connecting individual elements.

To ensure the adequacy of the mathematical model of the electromechanical system of the excavator, we present the mathematical models of the electric drives of the individual mechanisms of the excavator, Fig. 4, and the drive synchronous motor, Fig. 5, and the results of their work.

Mathematical modeling of the main elements of the electromechanical system of an excavator – DC machines and a synchronous drive motor – is a well-known studied problem, the solution of which is given in [15]. For mathematical modeling of the working processes of a drive synchronous motor, we use the well-known system of Park-Gorev equations in the orthogonal coordinate system $d, q, 0$ [16].

Of particular interest is the accepted version of the implementation of a closed-loop system for controlling the position of individual mechanisms of the excavator.

Fig. 3, *a* shows the implementation of a closed-loop control system for the position of a two-motor electric drive of the excavator platform swing mechanism. The closed-loop control system in this case is implemented according to the architecture of a classical control system with a common adder and negative feedback. Position control systems for other mechanisms are constructed similarly.

Fig. 3, *b* shows the results of mathematical modeling of the process of turning the platform at an angle of 120 degrees and returning to its original position. The numerical results of the angular velocity, armature current and generator voltage, shown in the corresponding graphs, coincide with the specifications of the electrical machines given in Tables 3, 4, which confirms the adequacy of the proposed implementation of a closed-loop position control system. The static and dynamic indicators of the quality of the position control of the turning mechanism are satisfactory and can be improved by complicating the structure of the position controller and its settings.

The results of modeling other mechanisms of the excavator are not given due to the limited scope of the publication and their triviality.

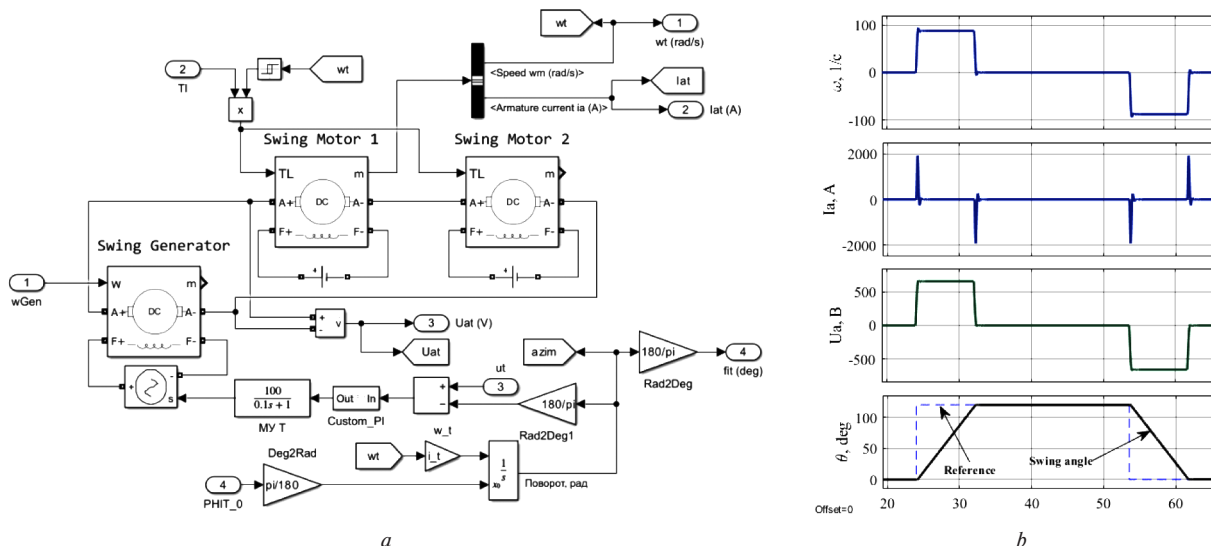

Fig. 3. Implementation of a closed-loop control system for the position of the excavator platform swing mechanism: a – block diagram of a closed-loop ACS; b – time diagrams for working out the movements of the excavator platform

In order to combine the mathematical models of individual mechanisms into an integral electromechanical system of the excavator, it is necessary to perform the following operations: connect the mechanical input of the DC generator units to the output of the angular velocity of the synchronous motor; determine the moment of resistance on the shaft of the drive synchronous motor. The moment of resistance on the SM shaft is equal to the total load from the DC generators of individual mechanisms and can be calculated by the expression

$$T_{LSM} = \frac{U_H \cdot I_H + U_C \cdot I_C + U_R \cdot I_R}{\omega_{LSM}}, \quad (8)$$

where $U_H, I_H, U_C, I_C, U_R, I_R$ are voltages and currents of generators of hoist, crowd and swing respectively; ω_{LSM} is an angular velocity of a synchronous motor.

The power consumption of the excavator is calculated as the total energy consumed from the supply network: at the terminals of the SM stator in the case of the Ward Leonard System electric drive, or on the primary winding of the mains transformer in the case of the TP-D electric drive.

Fig. 4 shows the proposed enlarged block diagram of a closed-loop ACS of the positioning of the excavator bucket, which includes a subsystem for generating the required trajectory of the bucket, determining the task for the position of individual mechanisms of the excavator by solving the inverse problem of the kinematics of the excavator, closed-loop control systems for the position of individual mechanisms, a subsystem for calculating the consumed electricity from the mains.

The positions of individual mechanisms of the excavator calculated during mathematical modeling using equations

(1–3) for the direct problem of kinematics make it possible to calculate the current position of the bucket in three-dimensional space and use the data obtained to implement a closed-loop control system for the position of the excavator bucket.

By setting the required trajectory of the bucket in three-dimensional space in the form of an array of points through which the bucket must pass, we, using the equations for solving the inverse problem of kinematics (4–7), calculate the necessary tasks for the position of individual mechanisms of the excavator, which are worked out by closed-loop control systems for the position of individual mechanisms.

The resulting implementation of the model of the integral electromechanical system of the excavator, including equations for solving the direct and inverse problems of the kinematics of the “face shovel” excavator, is shown in Fig. 5.

When performing the technological cycle of moving cargo with a help of an excavator, there are three characteristic points of the trajectory through which the bucket will necessarily pass: 1 – the digging start point; 2 – the digging completion point; 3 – the point of unloading the bucket into the vehicle.

The processes of moving the bucket from point 2 to point 3, as well as from point 3 to point 1, can be carried out along various trajectories, the process of moving the bucket in these modes is controlled by the driver, and the excavator’s energy consumption indicators significantly depend on the driver’s qualifications.

As an example, consider two bucket trajectories.

Trajectory 1. This trajectory is realized with the sequential movement of individual mechanisms. The sequence of movements is as follows: digging – turning to the unloading posi-

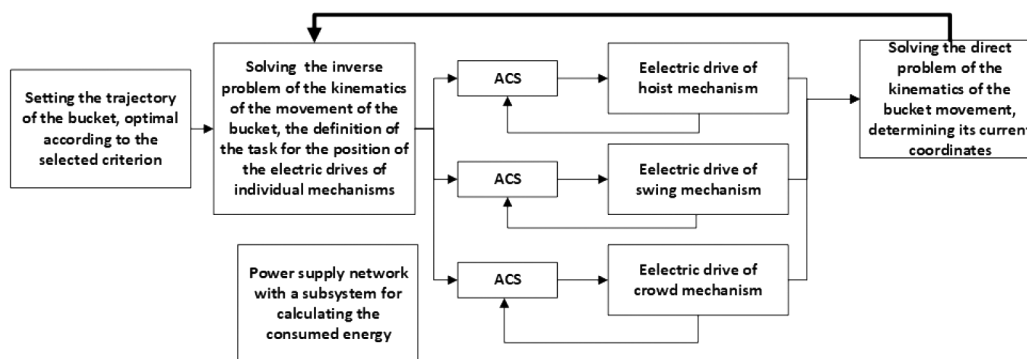

Fig. 4. Enlarged structural diagram of a closed-loop ACS for the positioning of the excavator bucket

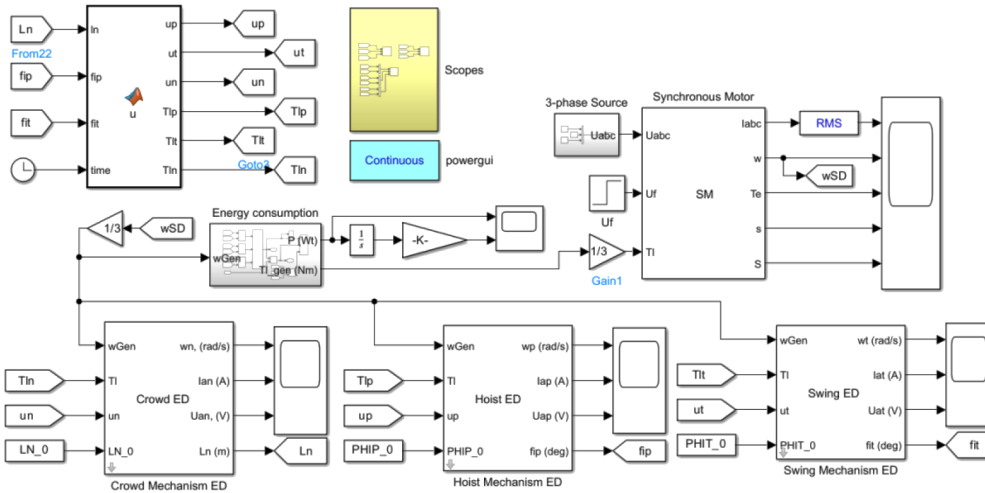

Fig. 5. Mathematical model of the complete electromechanical system of an excavator with electric drives of the main mechanisms according to the Leonard system

tion – lowering the bucket to the unloading point – turning to the starting position – lowering the bucket to the starting point.

Trajectory 2. The sequence of movements is as follows: digging – moving to the unloading point along a straight-line trajectory – moving to the starting position along a straight-

line trajectory. The implementation of such a trajectory requires the simultaneous coordinated operation of the electric drives of individual mechanisms.

Fig. 6 shows three-dimensional trajectories of the excavator bucket during the execution of the first *a* and second *b* trajectories, as well as time diagrams of the effective value of the stator

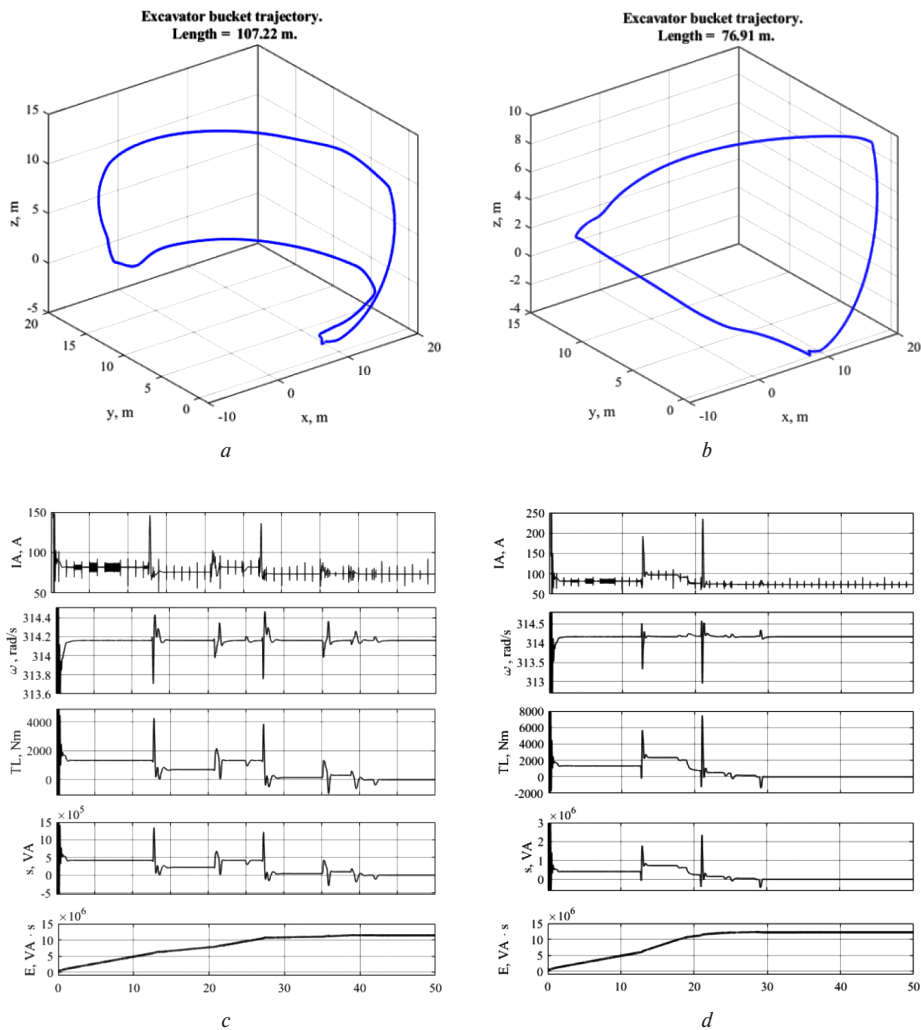

Fig. 6. Diagrams of the excavator operation during the full technological cycle:

a, b – trajectories of bucket; *c, d* – corresponding motion and power consumption diagrams of the drive synchronous motor

Table 6

Excavator performance indicators when performing different trajectories

Trajectory	Energy consumption, kVA·h	Trajectory length, m	Travel time, s
Trajectory 1	2.7547	106.04	40
Trajectory 2	3.3842	76.91	31

current of the SM, A , the angular velocity and moment of the moving SM, the instantaneous total power, VA , and the power consumed from the beginning of the production cycle, $VA \cdot s$, during the execution of the first c and second d trajectories.

A comparative analysis of the performance of the excavator when performing different trajectories is shown in Table 6.

As can be seen from Table 6, the length of trajectory 2 is reduced by 27.4 %, the execution time of trajectory 2 is reduced by 22.5 % compared to trajectory 1, but the power consumption of the excavator increases by 22.8 %.

From the obtained results, it can be hypothesized that the control for maximum speed is in conflict with the control for minimum power consumption.

The choice of the optimal trajectory of the excavator bucket requires the development of a special combined criterion that would take into account not only the change in energy consumption, but also the change in the performance of the excavator with a change in the length and duration of the technological cycle and is the subject of further research.

Conclusions. At the mining enterprises of Ukraine, which are characterized by high hardness of the extracted iron ore raw materials, electric excavators according to the “front shovel” scheme with the “generator-motor” system electric drive and the “TP-D” system electric drive succeeding it are most widely used.

Mathematical models of electric drives according to the G-M system of individual mechanisms of excavators and a drive synchronous motor are given. Combining the obtained models and taking into account the equations of the kinematics of the mechanical part of the excavator according to the “front shovel” scheme, a mathematical model of the integral electromechanical system of the excavator was obtained which makes it possible to proceed to the solution of the problem of creating a closed-loop system for controlling the position of the excavator bucket, to analyze the interconnected operation of individual mechanisms when performing the full technological cycle of the excavator; to determine the parameters of various trajectories of the bucket during the execution of the technological cycle.

It is shown that the reduction in the duration of the technological cycle of the excavator leads to an increase in the energy consumption of the excavator as a whole. With a reduction in the duration of the technological cycle by 22.5 %, the power consumption of the excavator increases by 22.8 %.

The choice of the optimal trajectory of the excavator bucket requires the development of a combined criterion that would take into account not only the change in energy consumption, but also the change in the performance of the excavator with a change in the length and duration of the technological cycle.

References.

1. Tiwari, R., Knowles, J., & Danko, G. (2013). Bucket trajectory classification of mining excavators. *Automation in Construction*, 31, 128-139. <https://doi.org/10.1016/j.autcon.2012.11.006>.
2. Wehrmeister, M.A., Freitas, E.P., Binotto, A.P.D., & Pereira, C.E. (2014). Combining aspects and object-orientation in model-driven engineering for distributed industrial mechatronics systems. *Mechatronics*, 24(7), 844-865. <https://doi.org/10.1016/j.mechatronics.2013.12.008>.
3. Litvin, O., Litvin, Ya., Tyulenev, M., & Markov, S. (2021). On determining the parameters of face blocks during mining operations with backhoes. *Gornaya promyshlennost – Russian Mining Industry*, (6), 76-81. <https://doi.org/10.30686/1609-9192-2021-6-76-81>.

4. Guan, D., Yang, N., Lai, J., Siu, M.-F.F., Jing, X., & Lau, C.-K. (2021). Kinematic modeling and constraint analysis for robotic excavator operations in piling construction. *Automation in Construction*, 126. <https://doi.org/10.1016/j.autcon.2021.103666>.
5. Tytiuk, V., Khandakji, K., Sivyakova, G., Karabut, N., Chorny, O., & Buser, V. (2021). Determining the parameters of the trajectory of the bucket of mining quarries excavators. *E3S Web Conference*, 280. *Second International Conference on Sustainable Futures: Environmental, Technological, Social and Economic Matters (ICSF 2021)*, 05013. <https://doi.org/10.1051/e3sconf/202128005013>.
6. Raza, M.A., & Frimpong, S. (2017). Mechanics of Electric Rope Shovel Performance and Reliability in Formation Excavation. In Canbolat, H. (Ed.). *Lagrangian Mechanics*. IntechOpen. <https://doi.org/10.5772/65333>.
7. Khorzoughi, B.M., & Hall, R. (2016). A Study of Digging Productivity of an Electric Rope Shovel for Different Operators. *Minerals*, 6(2), 48. <https://doi.org/10.3390/min6020048>.
8. Svanberg, A., Larsson, S., Rikard, M., & Pär, J. (2021). Full-Scale Simulation and Validation of Wear for a Mining Rope Shovel Bucket. *Minerals*, 11(6), 623. <https://doi.org/10.3390/min11060623>.
9. Svanberg, A., Larsson, S., Mäki, R., & Jonsén, P. (2021). Full-scale simulation and validation of bucket filling for a mining rope shovel by using a combined rigid FE-DEM granular material model. *Computational Particle Mechanics*, 8, 825-843. <https://doi.org/10.1007/s40571-020-00372-z>.
10. Kaltjob, P.O.J. (2021). *Control of Mechatronic Systems: Model-Driven Design and Implementation Guidelines*. Hoboken NJ: John Wiley & Sons. ISBN: 978-1-119-50575-4.
11. Kitzig, J., & Bumiller, G. (2019). Evaluation of Power Quality Measurement System Concept using an experimental setup. *2019 IEEE International Instrumentation and Measurement Technology Conference (I2MTC)*, 1-6. <https://doi.org/10.1109/I2MTC.2019.8826814>.
12. Wilamowski, B.M. (2017). *Control and Mechatronics (The Industrial Electronics Handbook)*. New York: CRC Press. ISBN 9781138073593.
13. Tytiuk, V., Lutsenko, I., Oksanych, I., & Rozhnenko, Zh. (2017). Development of the method for determining optimal parameters of the process of displacement of technological objects. *Eastern European Journal of Enterprise Technologies*, 6/3(90), 41-48. <https://doi.org/10.15587/1729-4061.2017.116788>.
14. Malafeev, S., Novgorodov, A., & Konyashin, V. (2020). Bench tests of the quarry excavators main electric drives. *2020 XI International Conference on Electrical Power Drive Systems (ICEPDS)*, 1-5. <https://doi.org/10.1109/ICEPDS47235.2020.9249257>.
15. Hughes, A., & Drury, B. (2013). *Electric motors and drives Fundamentals, Types, and Applications (4th ed.)*. Elsevier Ltd. ISBN: 978-0-08-098332-5.
16. Iqbal, A., Moinoddin, S., & Reddy, B.P. (2021). Synchronous Machines. In Iqbal, A., Moinoddin, S., & Reddy, B.P. (Eds.). *Electrical Machine Fundamentals with Numerical Simulation using MATLAB/SIMULINK*. <https://doi.org/10.1002/9781119682684.ch7>.

Математична модель замкнутої системи позиціонування ковша екскаватора

В. К. Титюк^{*1}, О. П. Чорний², В. В. Бушер³,
С. М. Трипутень⁴, М. М. Трипутень⁵, В. В. Кузнецов⁶

- 1 – НАТ «Карагандинський індустріальний університет», м. Теміртау, Республіка Казахстан
- 2 – Кременчуцький національний університет імені Михайла Остроградського, м. Кременчук, Україна
- 3 – Національний університет «Одеська Морська Академія», м. Одеса, Україна
- 4 – Neura Robotics GmbH, м. Метцинген, Федеративна Республіка Німеччина
- 5 – Національний технічний університет «Дніпровська політехніка», м. Дніпро, Україна
- 6 – Український державний університет науки та технологій, м. Дніпро, Україна

* Автор-кореспондент е-mail: v.tytyuk@ttu.edu.kz

Мета. Дослідження енергоспоживання мехатронних систем кар'єрних екскаваторів при виконанні повного експлуатаційного циклу, розробка критерію енергетич-

ної ефективності експлуатаційного циклу кар'єрних екскаваторів, що забезпечує підвищення техніко-економічних показників експлуатації потужного гірничодобувного обладнання.

Методика. Математичне моделювання електромеханічної системи екскаватора за схемою «пряма лопата», визначення показників експлуатаційного циклу, розробка критерію енергетичної ефективності експлуатаційного циклу кар'єрного екскаватора з урахуванням теорії ефективності технічних систем.

Результати. Розроблена математична модель цілісної електромеханічної системи екскаватора з електроприводом «генератор—двигун», що включає модель механічної частини екскаватора. Замкнена система управління положенням окремих механізмів дозволяє реалізувати різні траєкторії руху в ході виконання експлуатаційного циклу. Отримані числові характеристики енергоспоживання та тривалості для різних траєкторій руху робочих органів екскаватора. Запропоновано новий критерій енергетичної ефективності мехатронних систем кар'єрних екскаваторів.

Наукова новизна. Уперше запропонована математична модель цілісної електромеханічної системи екскавато-

ра за схемою «пряма лопата», що включає моделі електроприводів усіх механізмів і привідного синхронного двигуна, а також модель механічної частини екскаватора, що дозволило підвищити точність визначення енергоспоживання екскаватора й часу виконання експлуатаційного циклу. Запропоновано критерій енергетичної ефективності, що враховує величину ресурсних витрат, сукупного результату та тривалості виконання експлуатаційного циклу екскаватора.

Практична значимість. Розроблена математична модель електромеханічної системи екскаватора з електроприводом по системі «генератор—двигун», що, з урахуванням вирішення прямої та зворотної задачі кінематики механічної системи екскаватора, дозволяє порівнювати параметри різних траєкторій переміщення екскаватора. Запропоновано критерій енергетичної ефективності виконання технологічного циклу екскаватора, що враховує ресурсні витрати та тривалість технологічного циклу.

Ключові слова: екскаватор, математична модель, параметри траєкторії, енергетична ефективність

The manuscript was submitted 11.11.21.